

Regulatory Information Report

RIRF24039

**Fire resistance test for penetrations through
the vertical separating element**

Client: Agnitek Pty Ltd

Test method: AS1530.4-2014

Report Date: 29/06/2024

Test number: PF24039



Table of Contents

1.1	Document Revision Schedule	3
1.2	Signatories	3
2.	Report Summary.....	4
3.	General Information	5
3.1	Testing Scope	5
3.2	Contact Details.....	5
3.3	Specimen Preparation, Conditioning and Timeline	6
3.4	Use of Reports	7
4.	Specimen Description.....	8
4.1	Supporting Construction.....	8
4.2	Specimens	9
5.	Specimens.....	13
5.1	Specimen 1	13
5.2	Specimen 2	14
5.3	Specimen 3	15
5.4	Specimen 4	16
5.5	Specimen 5	17
5.6	Specimen 6	19
5.7	Specimen 7	20
5.8	Specimen 8	21
6.	Observations during the test.....	23

1.1 Document Revision Schedule

Revision #	Date	Description
1	29/06/2024	Issued to Client

1.2 Signatories

Report	Name	Signature	Date
Prepared by:	Alexey Kokorin		29/06/2024
Authorised by:	Andrew Bain (Authorized signatory)		29/06/2024



All tests reported herein have been performed in accordance with the laboratory's scope of accreditation

2. Report Summary

Service penetration 1 to 5 were tested passing through a 92mm steel stud wall with one layer of 13mm FR plasterboard each side. Service penetration 6 to 8 were tested passing through a 150mm thick concrete separating element.

Specimen #	Service	Actual Integrity (min)	Actual Insulation (min)	FRL
1	42mm OD Steel Pipe	91 NF	69	-/60/60*
2	DN32 PE-Xa Pipe	91 NF	12	-/60/-*
3	DN20 PE-Xb Pipe	91 NF	67	-/60/60*
4	DN16 PE-Xb Pipe	91 NF	65	-/60/60*
5	3xDN100 PVC-U DWV Pipe	91 NF	91 NF	-/60/60*
6	3xPair coil + 1x50NB copper pipe	82	77	-/60/60
7	90mm PPR Pipe	91 NF	91 NF	-/90/90
8	90mm PPR Pipe with 90° Elbow	91 NF	91 NF	-/90/90

NF – No failure during the test

* - limited by the stated performance of the separating element

3. General Information

3.1 Testing Scope

Applicable Standards:

AS 1530.4-2014 Section 10: Service penetrations and control joints

AS 4072.1-2005 (r. 2016) Components for the protection of openings in fire-resistant separating elements. Part 1: Service penetrations and control joints

Departures from Testing Method:

There were no departures from the testing method.

Test conditions:

Conditions complied with the Standard.

3.2 Contact Details

Accredited testing laboratory

Fire TS Lab - Passive Fire Inspection and Test Services Ltd

Accreditation Number - 1335

1/113 Pavilion Drive, Mangere, Auckland, 2022

New Zealand

Contact e-mail: tests@firelab.co.nz

Client/Applicant:

Agnitek Pty Ltd

8 Clare St, Bayswater, VIC, 3153

Australia

Contact e-mail: info@agnitek.com.au

Manufacturer:

Same as Client/Applicant

3.3 Specimen Preparation, Conditioning and Timeline

Specimens conditioning and delivery to Laboratory:

Separating element was built by the Laboratory in line with Client instructions. Installation of fire stopping system was performed by the Laboratory in line with Client instructions. The Laboratory was not involved in sampling of the materials. The Laboratory checked materials during construction of the specimen.

Testing date:

21/03/2024

Installation completion date:

18/03/2024

Termination of The Test:

The test was discontinued at 91 minutes.

3.4 Use of Reports

A regulatory information report was issued in addition to the full test report PF24039. This provides the minimum information required for regulatory compliance.

This report shall not be reproduced, except in full.

The specimen was a symmetrical construction.

This report details the methods of construction, test conditions and the results obtained when the specific element of construction described herein was tested following the procedure outlined in AS 1530.4. Any significant variation with respect to size, constructional details, loads, stresses, edge or end conditions, other than that allowed under the field of direct application in the relevant test method, is not covered by this report.

Because of the nature of fire resistance testing and the consequent difficulty in quantifying the uncertainty of measurement of fire resistance, it is not possible to provide a stated degree of accuracy of the result.

The test results relate to the specimens of the product in the form in which they were tested. Differences in the composition or thickness of the product may significantly affect the performance during the test and may therefore invalidate the test results. Care should be taken to ensure that any product, which is supplied or used, is fully represented by the specimens, which were tested.

The specimens were supplied by the sponsor and the Laboratory was not involved in any of selection or sampling procedures.

The results of these fire tests may be used to directly assess fire hazard, but it should be recognized that a single test method will not provide a full assessment of fire hazard under all fire conditions.

4. Specimen Description

4.1 Supporting Construction

Separating element		
1.1	Item	92mm Steel Stud with one layer of 13mm FR plasterboard each side on top of a 150mm thick concrete slab
	Dimensions	Overall Width / Height (W/H): 1200mm x 1200mm
		Plasterboard Wall Thickness (T): 118mm
		Plasterboard Wall Cavity: 92mm
		Concrete wall Thickness: 150mm

Materials		
1.2	Item	Steel Track
	Dimensions	Width / Height (W/H): 92mm x 32mm
		Thickness (T): 0.55 BMT
	Additional Info	Used to construct steel stud frame
1.3	Item	Steel Stud
		Width / Height (W/H): 92mm x 50mm
		Thickness (T): 0.50 BMT
	Additional Info	Fixed to steel tracks, used to construct steel stud frame
1.4	Item	Concrete Pin Anchors
	Dimensions	6.5mm x 32mm
	Installation	Used to fix steel track to refractory frame
1.5	Item	AGNI-Board
	Dimensions	Width / Height (W/H): 600mm x 1200mm
		Thickness (T): 50mm
		Density (ρ): 160 kg/m ³ nominal, 190.95 kg/m ³ measured
	Installation	Installed to steel stud frame between specimens, trimmed to flush with steel studs
	Item	Fire Rated Plasterboard

1.6	Dimensions	Width / Height (W/H): 1200mm x 700mm
		Thickness (T): 13mm
	Additional Info	1 x layer installed to each face of steel stud frame
1.7	Item	Self-Tapping Screw
	Dimensions	6g x 25mm
	Installation	Used to construct steel stud frame
1.8	Item	Self Tapping Screw
	Dimensions	6g x 41mm
	Installation	Used to fix plasterboard to steel stud frame
1.9	Item	150mm Concrete Slab
	Dimensions	Width / Height (W/H): 1200mm x 500mm
	Installation	Fixed to the bottom of refractory frame

4.2 Specimens

Services		
2.1	Item	35NB Steel Pipe
	Dimensions	Inner Diameter (ID): 35mm
		Outer Diameter (OD): 42mm
		Thickness (T): 3mm
2.2	Item	Pipe DN32 PE-Xa Pipe
	Dimensions	Inner Diameter (ID): 22.5mm
		Outer Diameter (OD): 32.5mm
		Thickness (T): 5mm
2.3	Item	DN20 PE-Xb Pipe
	Dimensions	Inner Diameter (ID): 14.5mm
		Outer Diameter (OD): 20mm
		Thickness (T): 3.5mm
2.4	Item	DN16 PE-Xb Pipe
	Dimensions	Inner Diameter (ID): 11.5mm
		Outer Diameter (OD): 16mm

		Thickness (T): 2.5mm
2.5	Item	DN100 PVC-U Pipe
	Dimensions	Inner Diameter (ID): 103.5mm
		Outer Diameter (OD): 111mm
	Thickness (T): 3.5mm	
2.6	Item	Copper Pair coil 3/4" + 3/8"
	Dimensions	Overall Width / Height (W/H): 68mm x 38mm
		PE Thickness (T): 8.5mm
2.7	Item	50NB Copper Pipe
	Dimensions	Inner Diameter (ID): 50mm
		Outer Diameter (OD): 54mm
	Thickness (T): 1.5mm	
2.8	Item	90mm PPR Pipe
	Dimensions	Inner Diameter (ID): 71.5mm
		Outer Diameter (OD): 90mm
	Thickness (T): 9.5mm	
2.9	Item	PPR 90mm 90° Elbow
	Dimensions	Inner Diameter (ID): 90mm
		Outer Diameter (OD): 119.5mm
	Thickness (T): 14.5mm	

Sealants

3.1	Item	AGNI-Seal
	Dimensions	600mL sausage
	Installation	Applied to AGNI-Board and installed in annular space

Fixings

4.1	Item	AGNI-Strap - Stainless Cable Tie
	Dimensions	Width (W): 4.6mm x 200mm
	Installation	Used to fix AGNI-Wrap and AGNI-Sleeve

4.2	Item	AGNI-Clip - Stainless steel Clips
	Installation	Used to fix AGNI-Wrap to separating element
4.3	Item	Self Tapping Screw
	Dimensions	6g x 25mm
	Installation	Used to fix AGNI-Wrap to separating element
4.4	Item	1/4"x2-3/4" Slotted head hex screw
	Dimensions	6mmx69.5mm
	Installation	Used to fix AGNI-Board to concrete separating element
4.5	Item	21x1.6mm Penny Washer
	Dimensions	Outer Diameter (OD): 20mm
	Installation	Used with slotted head hex screw to fix AGNI-Board to concrete separating element
4.6	Item	Spiral Pig Tail Screw
	Dimensions	100mmx18mm
	Installation	Used to fix AGNI-Board to AGNI-Board

Fire Board

5.1	Item	AGNI-Board
	Dimensions	Width / Height (W/H): 600mm x 1200mm
		Thickness (T): 50mm
		Density (ρ): 160 kg/m ³ nominal 190.95 kg/m ³ measured

Backing

6.1	Item	Ceramic Fibre (AGNI-Shield with foil removed)
	Dimensions	Thickness (T): 16mm
		Density (ρ): 121.6 kg/m ³
Installation	Installed in annular space	

Fire Wrap		
8.1	Item	AGNI-Shield - Foil faced (one side) ceramic fibre
	Dimensions	Thickness (T): 16mm
		Ceramic fibre density (ρ): 121.6 kg/m ³
Installation	AGNI-Shield wrapped around service and secured with cable ties	

Intumescent		
9.1	Item	AGNI-Wrap
	Dimensions	Width (W): 25mm
		Thickness (T): 3mm
Installation	Installed around service	
9.2	Item	AGNI-Sleeve
	Thickness	3mm
	Installation	Installed around service

5. Specimens

5.1 Specimen 1

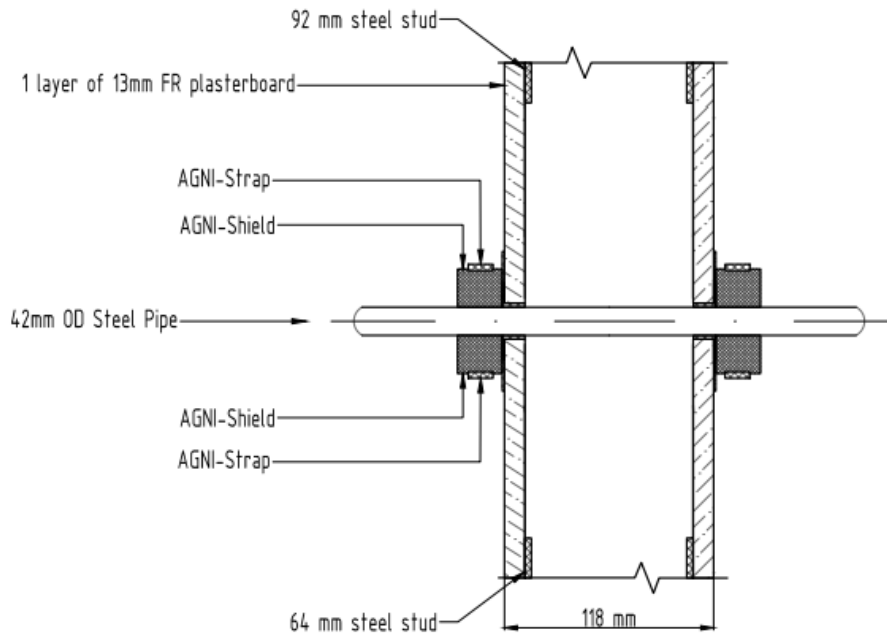

Figure 3 – Specimen 1

Service penetration details	
Service	42mm OD Steel Pipe
Aperture Diameter	51mm
Annular Spacing	Min: 0mm, Max: 9mm

Local Fire-stopping system	
Application	Symmetrical – installed on both faces of separating element
System description	13mm (nominal) deep AGNI-Seal was installed in annular space. A 50mm wide AGNI-Shield was wrapped twice around the pipe and secured with a cable tie at mid-width, against the separating element. AGNI-Seal was applied to the joint between the wrap and separating element.

Test results

Structural adequacy	Not applicable
Integrity	No failure at 91 minutes
Insulation	69 minutes

5.2 Specimen 2

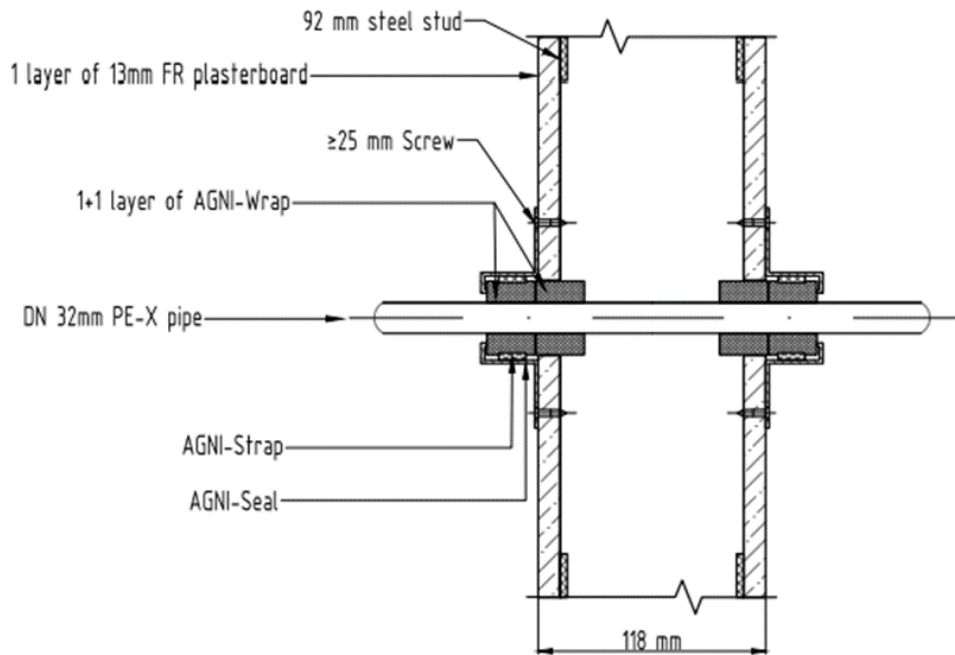

Figure 5 – Specimen 2

Service penetration details	
Service	DN32 PE-Xa Pipe
Aperture Diameter	44mm
Annular Spacing	Min: 3mm, Max: 8.5mm

Local Fire-stopping system	
Application	Symmetrical – installed on both faces of separating element
System description	One layer of AGNI-Wrap was installed around the pipe in the annular space, flush with separating element. Another single layer AGNI-Wrap was wrapped around the pipe with 10mm overlap then secured with a cable tie and fixed to the separating element with 2 screw and AGNI-Clips.

Test results

Structural adequacy	Not applicable
Integrity	No failure at 91 minutes
Insulation	12 minutes

5.3 Specimen 3

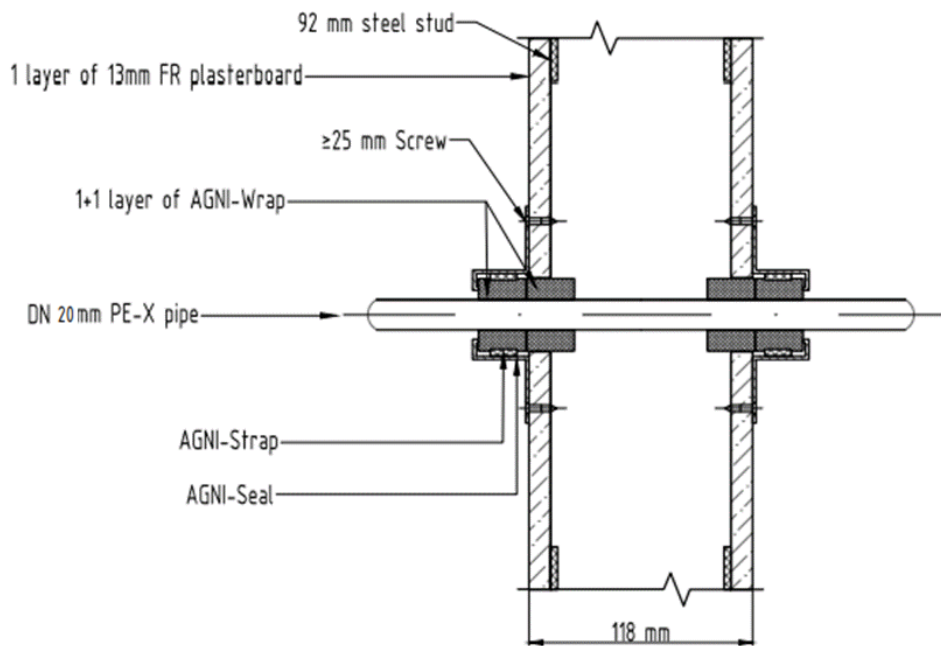

Figure 7 – Specimen 3

Service penetration details	
Service	DN20 PE-Xb Pipe
Aperture Diameter	30mm
Annular Spacing	Min: 4mm, Max: 6mm

Local Fire-stopping system	
Application	Symmetrical – installed on both faces of separating element
System description	One layer of AGNI-Wrap was installed around the pipe in the annular space, flush with separating element. Another single layer AGNI-Wrap was wrapped around the pipe with 10mm overlap then secured with a cable tie and fixed to the separating element with 2 screw and AGNI-Clips.

Test results

Structural adequacy	Not applicable
Integrity	No failure at 91 minutes
Insulation	67 minutes

5.4 Specimen 4

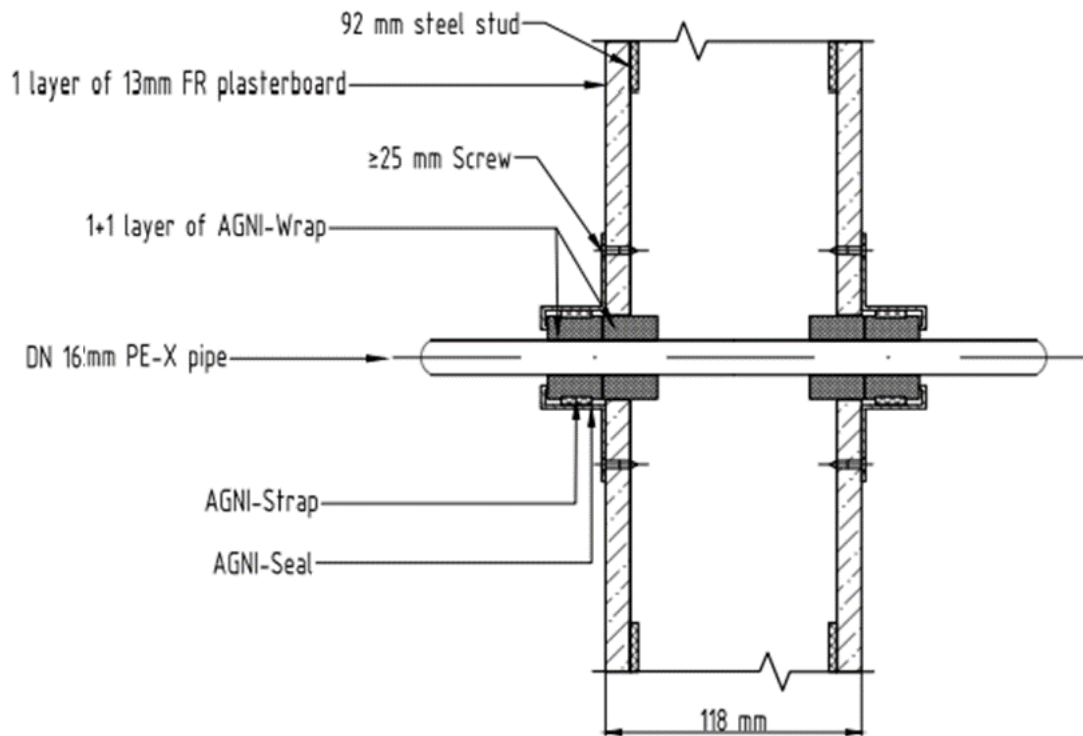

Figure 9 – Specimen 4

Service penetration details	
Service	DN16 PE-Xb Pipe
Aperture Diameter	30mm
Annular Spacing	Min: 4mm, Max: 10mm

Local Fire-stopping system	
Application	Symmetrical – installed on both faces of separating element
System description	One layer of AGNI-Wrap was installed around the pipe in the annular space, flush with separating element. Another single layer AGNI-Wrap was wrapped around the pipe with 10mm overlap then secured with a cable tie and fixed to the separating element with 2 screw and AGNI-Clips.

Test results

Structural adequacy	Not applicable
Integrity	No failure at 91 minutes
Insulation	65 minutes

5.5 Specimen 5

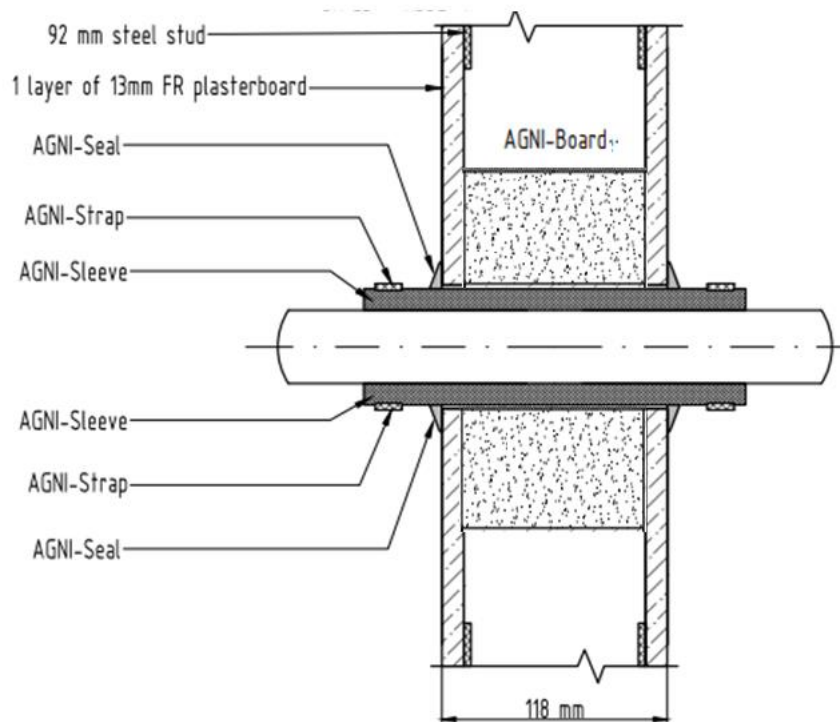

Figure 11 – Specimen 5

Service penetration details	
Service	3 × DN100 PVC-U DWV Pipe
Aperture Size	Width / Height (W/H): 400mm × 125mm
Annular Spacing	Min: 3mm, Max: 38mm

Local Fire-stopping system	
Application	Asymmetrical
System description	Two pieces of 180mm×110mm AGNI-Sleeve were installed between each pipe. A 865mm×180mm AGNI-Sleeve was wrapped around the bundle and fixed with cable ties at both sides of the wall. Two layers of 510mm×310mm(W/H) AGNI-Board with a 355mm×130mm(W/H) aperture was installed around the pipes, from exposed side, against the plasterboard on unexposed side. AGNI-Coat was applied to all edges of AGNI-Boards. AGNI-Seal was applied over AGNI-Board joints and between AGNI-Board and the pipes, flush with AGNI-Board. From both sides, AGNI-Seal was installed in annular space, flush with plasterboard, and a bead of sealant was applied between AGNI-Sleeves to seal existing gaps.

Test results

Structural adequacy	Not applicable
Integrity	No failure at 91 minutes
Insulation	No failure at 91 minutes

5.6 Specimen 6

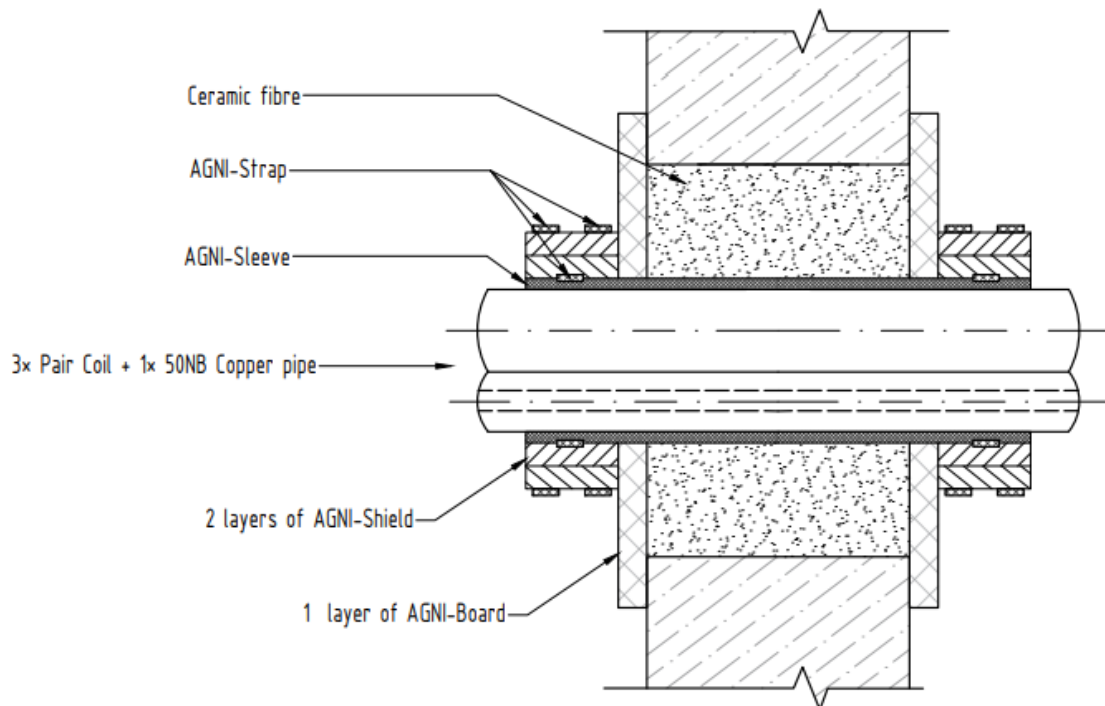

Figure 13 – Specimen 6

Service penetration details	
Service	3 x Pair coil and 1 x 50NB copper pipe
Aperture Diameter	170mm
Annular Spacing	Min: 10mm, Max: 55mm

Local Fire-stopping system	
Application	Symmetrical – installed on both faces of separating element
System description	A 330mm x 430mm AGNI-Sleeve was fixed around the bundle with cable ties. Ceramic fibre was installed in annular space, 10mm from both faces of separating element. 10mm (nominal) deep seal was installed in annular space. A 270mm x 270mm AGNI-Board with a 170mm aperture was cut in half and installed around the bundle against the separating element. AGNI-Seal was applied between AGNI-Board and separating element, to AGNI-Board joint, and to AGNI-Board and bundle junction. AGNI-Coat was applied over AGNI-Board joint, edges and fixings. Two layers of 300mm wide AGNI-Shield was installed around the bundle and fixed with cable ties. AGNI-Seal was applied to wrap and board junction.

Test results

Structural adequacy	Not applicable
Integrity	82 minutes
Insulation	77 minutes

5.7 Specimen 7

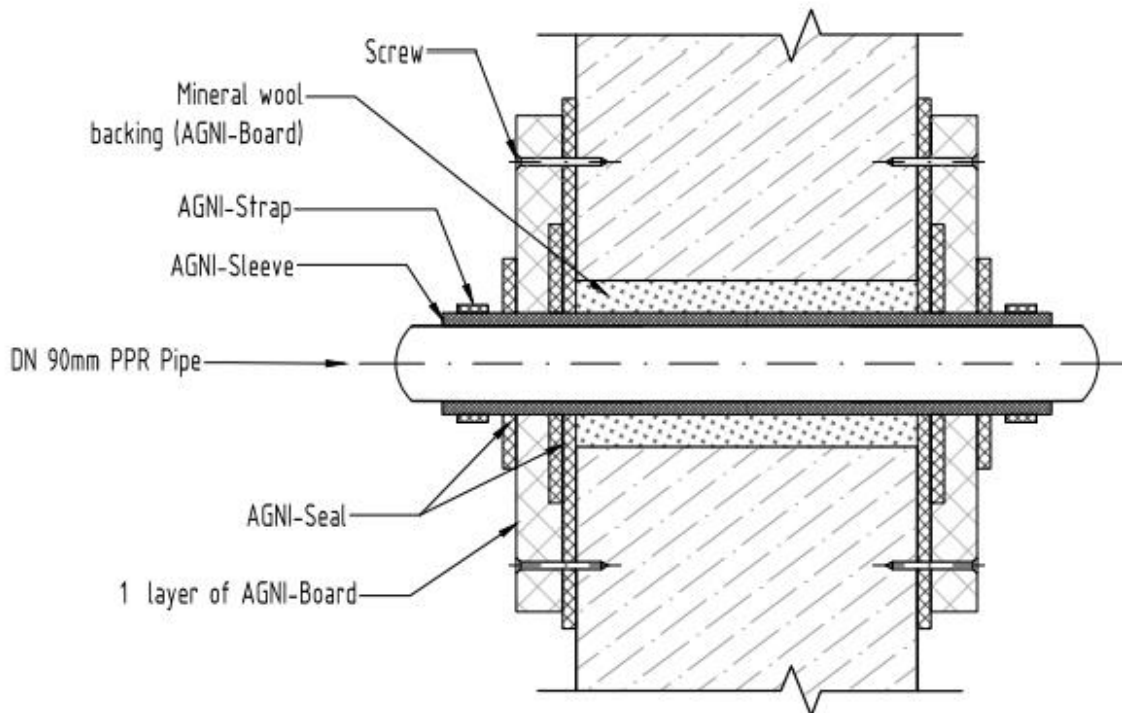

Figure 15 – Specimen 7

Service penetration details	
Service	90mm PPR Pipe
Aperture Diameter	160mm
Annular Spacing	Min: 5mm, Max: 65mm

Local Fire-stopping system	
Application	Symmetrical – installed on both faces of separating element
System description	A 330mm x 330mm AGNI-Sleeve was fixed around the pipe with cable ties. Ceramic fibre was installed in annular space, 10mm from both faces of separating element. 10mm (nominal) deep seal was installed in annular space. A 220mmx240mm (W/H) AGNI-Board with a 93mm aperture was cut in half and installed around the pipe against the separating element.

	AGNI-Seal was applied between AGNI-Board and separating element, to AGNI-Board joint and to the AGNI-Board and pipe junction. AGNI-Coat was applied over AGNI-Board joint, edges and fixings.
--	---

Test results

Structural adequacy	Not applicable
Integrity	No failure at 91 minutes
Insulation	No failure at 91 minutes

5.8 Specimen 8

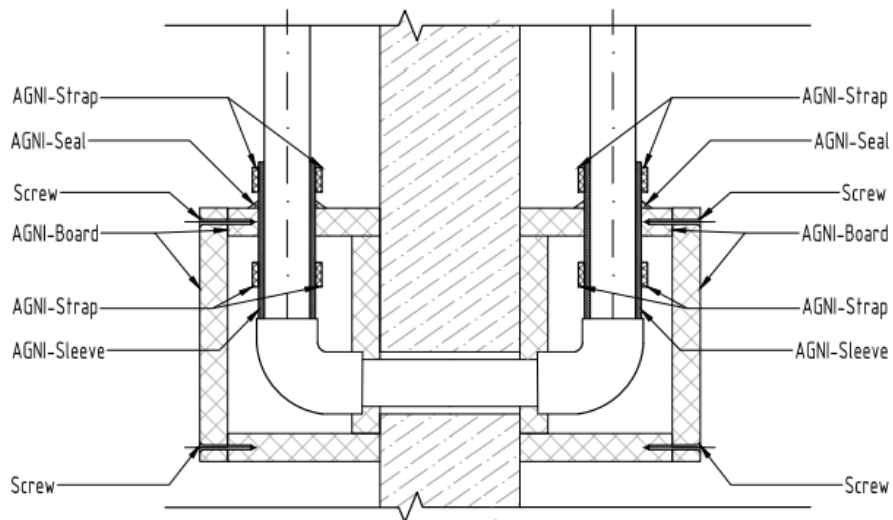

Figure 17 – Specimen 8

Service penetration details	
Service	90mm PPR Pipe with 90° Elbow
Aperture Diameter	100mm
Annular Spacing	5mm
Local Fire-stopping system	
Application	Symmetrical – installed on both faces of separating element
System description	A 145x50mm AGNI-Boards was fixed to separating element on left and right side of the elbow. A 220mmx50mm AGNI-Board was fixed to separating element on the top and bottom side of the elbow. The top AGNI-Board was trimmed to fit the pipe. A 340mmx200mm AGNI-Sleeve was installed around the pipe, above the elbow. An AGNI-Board box with 145mmx240mm

	AGNI-Board on the sides, 145mm×320mm top and bottom board, 340mm×320mm front board and an additional 200mm×320mm top board, was installed around the elbow, against the separating element, with the pipe penetrating through the top AGNI-Boards. AGNI-Seal was installed between AGNI-Board and separating element, between AGNI-Board and the elbow, to AGNI-Board joints and edges, and to AGNI-Board and pipe junction. AGNI-Coat was applied to box and separating element junction, and over AGNI-Board joints, edges and fixings on the outer surface of the box.
--	---

Test results

Structural adequacy	Not applicable
Integrity	No failure at 91 minutes
Insulation	No failure at 91 minutes



6. Observations during the test

Time min	Test face	SP#	OBSERVATIONS/REMARKS
5	U	5	Deformation of all pipes, cotton pad test for 30 seconds over red glowing in aperture – PASS
82	U	6	Visible flame > 10 seconds from space between wrap and bundle with discolouring and cracking of sealant on wrap and board junction
91			Test Discontinued

NOTE: E – Exposed Face (inside furnace)
U – Unexposed Face (outside furnace)
SE – Separating element